



ELITE ROBOTS



# EC68-08 | 6-axis Collaborative Robot

EC SERIES



8kg  
Payload



820mm  
Radius



$\pm 0.03$ mm  
Repeatability



2.5m/s  
Max TCP Speed

# EC68-08

## EC SERIES



### Robotic Arm

<b>Payload</b>	8kg
<b>Radius</b>	820mm
<b>Repeatability</b>	±0.03mm
<b>Axis</b>	6
<b>Joints rotation</b>	J1-J6 ±360°
	J1-J2 150°/s
<b>Joints speed</b>	J3 190°/s
	J4-J6 260°/s
<b>Max TCP Speed</b>	2.5m/s
<b>IP rating</b>	IP54
<b>Operating Temperature range</b>	0-50 °C
<b>Relative humidity</b>	5%-95% (non-condensing)
<b>Typical power usage</b>	250w
<b>Mounting</b>	Any angle
<b>Tool I/O connector</b>	12 pin
<b>Tool I/O ports</b>	2 DI, 2 DO, 1 AI, 1 AO
<b>Tool I/O power supply</b>	24 V
<b>Tool I/O communication</b>	RS485
<b>Footprint</b>	Ø 150 mm
<b>Weight</b>	17kg
<b>Material</b>	Aluminum, Steel
<b>Cable length</b>	5.5m
<b>Certifications</b>	EN ISO 10218-1

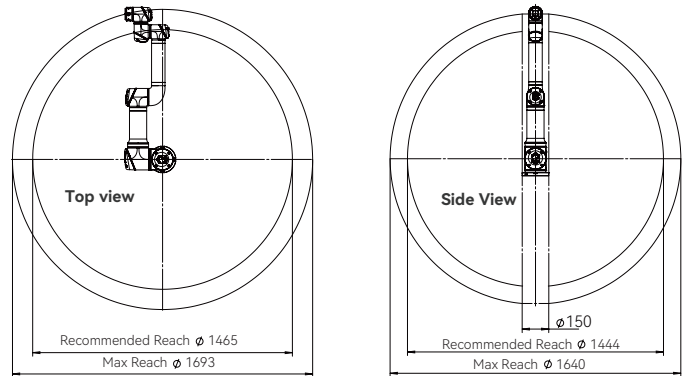
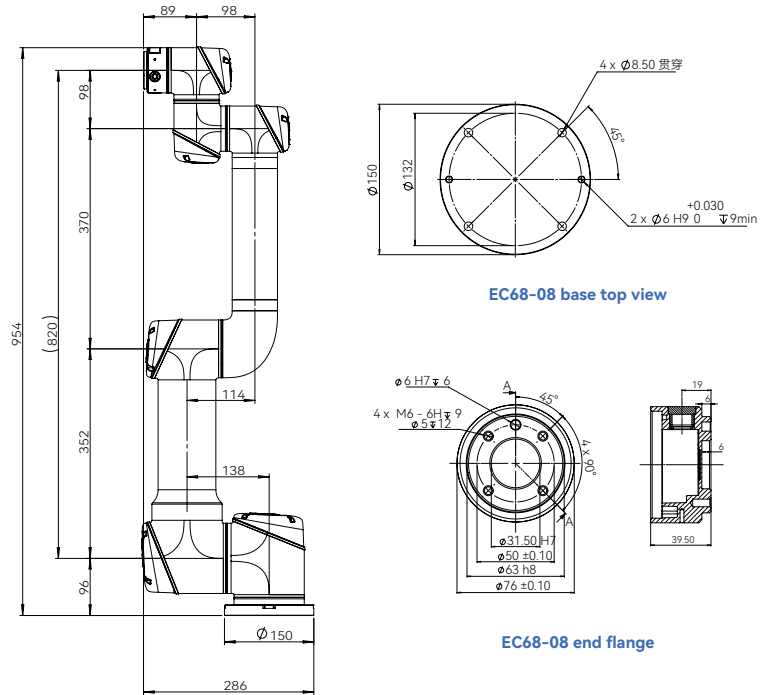

### Teach-Pendant



<b>Size</b>	290mm x 225mm x 118mm
<b>Screen display size</b>	12.1"
<b>Resolution</b>	1280 x 800 pixels
<b>Material</b>	Aluminum, Plastic
<b>Weight</b>	1.8 kg
<b>Cable length</b>	5.5 m
<b>IP rating</b>	IP54
<b>Input method</b>	Resistive touch-screen, physical buttons

### Controller

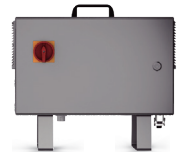

<b>Size</b>	505mm x 448mm x 245mm
<b>Material</b>	Aluminum, Steel
<b>IP rating</b>	IP44
<b>I/O ports</b>	16 DI, 16 DO, 2 AI, 4 AO
<b>I/O power supply</b>	24V; 2A (internal)
<b>Communication ports</b>	1 Ethernet port, 1 RS485/RS232, 1 USB 2.0
<b>Communication protocols</b>	TCP/IP, MODBUS TCP/RTU, EtherNet/IP, Profinet, CCLink
<b>Power source</b>	100-240 VAC, 50-60 Hz (M: 19-72VDC)